

Band saw machine with single-sided working table (for meat processing)

A16SW

AKIYAMA

- High yield ratio by the outstanding high-speed blade
- Safety devices equipped as standard
- Sliding table for accurate cutting of foodstuff



- Standard equipment devices
 - Signal light tower indicating operational conditions
 - Door closing prevention device
 - Trash box
 - Fine adjustment ruler
- Optional equipment
 - Material hold down fittings
 - Table stroke changer

The machine equipped with a slide table for constant dimension slicing to our compact band saw machine, model **A16** (sales record exceeds 1,000 units) which has an established reputation as a band saw machine for marine products processing. **A16SW** is the best one for slicing of frozen meat and frozen meat blocks.

Food Processing Band Saw

A16SW

High-speed rotation ensures clean cut surfaces.

A16SW was created for meat-cutting band saws by utilizing technology cultivated through the manufacture of marine products processing machinery. The saw blade speed is significantly faster than that of conventional meat band saw machines, resulting in a higher yield. The cutting surface is extremely smooth and clean. The speed of the band saw blade can be selected according to the food to be processed.

Most suitable for constant dimension cutting

Slide table type is convenient for cutting food materials in constant dimension. A fine-adjustment ruler is also included as standard equipment. Foodstuff can be cut safely and efficiently.

Motor Direct Drive Pulley

Since the wheel rotates by direct drive, there is no power loss, and the band saw's rotational noise and vibration are reduced.

Safety designed

An emergency stop button is provided in case of emergency. Pressing the button quickly stops the rotation of the band saw blade. The brake is applied as soon as the switch is turned off, thanks to the drive pulley directly connected to the motor. In addition, a signal light, door closing prevention device, and waste receptacle installation prevention device are provided as standard equipment.

Equipped with stainless steel wheels

Stainless steel cast wheels are applied as standard component to ensure high speed rotation and hygiene.

Space-saving design

This machine occupies only 960 mm x 1100 mm of space, making it ideal for use in small backyards.

Washable and hygienic

Main body is made of all stainless steel, making it highly resistant to corrosion, water, salt, and rust, and hygienic. It can be easily washed with water.

Specifications can be changed

Specifications of this machine can be modified to meet your needs, such as changing the table stroke or motor horsepower. Please feel free to contact us.



•Machine size

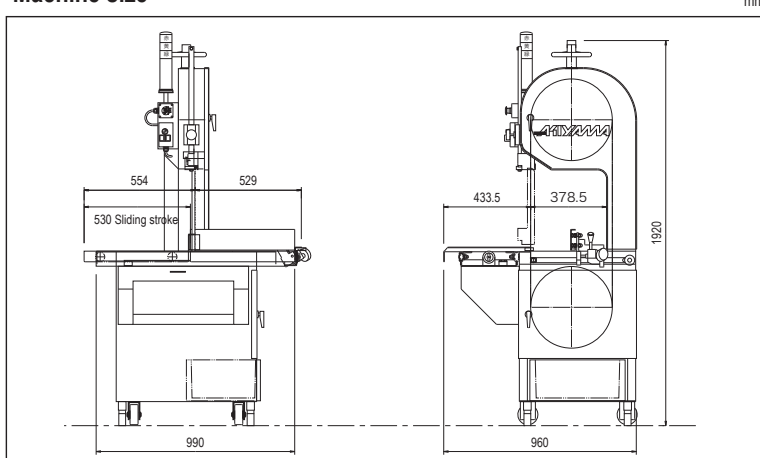

•Specifications

Max. processable height	390mm
Table size	430 × 650 mm
Table height	870 mm
Machine size (W x D x H)	960×1100×1920mm
Machine weight	350kg
Motor	2.2kw × 4p
Power supply	200V 50/60Hz
Blade speed (standard/high speed)	2050/2425 m/min

We are constantly striving to improve our products, so the photos and specifications in this leaflet may differ slightly from the delivered products. Please understand this in advance.

AKIYAMA Machinery Co., Ltd.

1-30-10, Kitamariko, Suruga-ku, Shizuoka-shi,
Shizuoka, 421-0106, JAPAN
Phone. +81-54-259-2779 Facsimile. +81-54-259-2995
<https://www.akiyamakikai.co.jp/en/>